



Programmable Controller
MELSEC-F

FX3U SERIES PROGRAMMABLE CONTROLLERS

HARDWARE MANUAL



Manual Number	JY997D50301
Revision	E
Date	March 2018

This manual describes the part names, dimensions, mounting, cabling and specifications for the product. This manual is extracted from FX3U Series User's Manual - Hardware Edition. Refer to FX3U Series User's Manual - Hardware Edition for more details. Before use, read this manual and manuals of relevant products fully to acquire proficiency in the handling and operating the product. Make sure to learn all the product information, safety information, and precautions.

And, store this manual in a safe place so that you can take it out and read it whenever necessary. Always forward it to the end user.

Registration

The company name and the product name to be described in this manual are the registered trademarks or trademarks of each company.

Effective March 2018

Specifications are subject to change without notice.

© 2013 Mitsubishi Electric Corporation

Safety Precaution (Read these precautions before use.)

If the equipment is used in a manner not specified by the manufacturer, the protection provided by the equipment may be impaired.

This manual classifies the safety precautions into two categories:

WARNING and **CAUTION**.

WARNING	Indicates that incorrect handling may cause hazardous conditions, resulting in death or severe injury.
CAUTION	Indicates that incorrect handling may cause hazardous conditions, resulting in medium or slight personal injury or physical damage.

Depending on the circumstances, procedures indicated by

CAUTION may also cause severe injury.

It is important to follow all precautions for personal safety.

STARTUP AND MAINTENANCE PRECAUTIONS	WARNING
<ul style="list-style-type: none"> Do not touch any terminal while the PLC's power is on. Doing so may cause electric shock or malfunctions. 	

STARTUP AND MAINTENANCE PRECAUTIONS	WARNING
<ul style="list-style-type: none"> Before cleaning or retightening terminals, cut off all phases of the power supply externally. Failure to do so may cause electric shock. Before modifying or disrupting the program in operation or running the PLC, carefully read through this manual and the associated manuals and ensure the safety of the operation. An operation error may damage the machinery or cause accidents. Do not change the program in the PLC from two or more peripheral equipment devices at the same time. (i.e. from a programming tool and a GOT) Doing so may cause destruction or malfunction of the PLC program. Use the battery for memory backup correctly in FX3U Series User's Manual - Hardware Edition. <ul style="list-style-type: none"> Use the battery only for the specified purpose. Connect the battery correctly. Do not charge, disassemble, heat, put in fire, short-circuit, connect reversely, weld, swallow or burn the battery, or apply excessive forces (vibration, impact, drop, etc.) to the battery. Do not store or use the battery at high temperatures or expose to direct sunlight. Do not expose to water, bring near fire or touch liquid leakage or other contents directly. Incorrect handling of the battery may cause heat excessive generation, bursting, ignition, liquid leakage or deformation, and lead to injury, fire or failures and malfunctions of facilities and other equipment. When replacing the battery, make sure to use our specified product (FX3U-32BL). When a battery error occurs ("BATT" LED is lit in red), follow the description in FX3U Series User's Manual - Hardware Edition. 	

STARTUP AND MAINTENANCE PRECAUTIONS	CAUTION
<ul style="list-style-type: none"> Turn off the power to the PLC before attaching or detaching the memory cassette. If the memory cassette is attached or detached while the PLC's power is on, the data in the memory may be destroyed, or the memory cassette may be damaged. Do not disassemble or modify the PLC. Doing so may cause fire, equipment failures, or malfunctions. For repair, contact your local Mitsubishi Electric distributor. Turn off the power to the PLC before connecting or disconnecting any extension cable. Failure to do so may cause equipment failures or malfunctions. Turn off the power to the PLC before attaching or detaching the following devices. Failure to do so may cause equipment failures or malfunctions. <ul style="list-style-type: none"> Display module, peripheral devices, expansion boards, and special adapters Connector conversion adapter, extension blocks, and FX Series terminal blocks Battery and memory cassette Do not use the chemicals for cleaning. If there is the possibility of touching the PLC inside a control panel in maintenance, make sure to discharge to avoid the influence of static electricity. Since there are risks such as burn injuries, please do not touch the surface of the equipment with bare hands when it is operating in an environment which exceeds ambient temperature of 50°C. 	

TRANSPORTATION AND STORAGE PRECAUTIONS	CAUTION
<ul style="list-style-type: none"> Please contact a certified electronic waste disposal company for the environmentally safe recycling and disposal of your device. When disposing of batteries, separate them from other waste according to local regulations. (For details of the Battery Directive in EU countries, refer to FX3U Series User's Manual - Hardware Edition.) Before transporting the PLC, turn on the power to the PLC to check that the BATT LED is off. If the PLC is transported with the BATT LED on or the battery exhausted, the battery-backed data may be unstable during transportation. The PLC is a precision instrument. During transportation, avoid impacts larger than those specified in Section 2.1 by using dedicated packaging boxes and shock-absorbing palettes. Failure to do so may cause failures in the PLC. After transportation, verify operation of the PLC and check for damage of the mounting part, etc. When transporting lithium batteries, follow required transportation regulations. (For details of the regulated products, refer to FX3U Series User's Manual - Hardware Edition.) 	

Associated manuals

How to obtain manuals
For the necessary product manuals or documents, consult with your local Mitsubishi Electric representative.

Associated manuals

FX3U Series PLC (main unit) comes with this document (hardware manual).

For a detailed explanation of the FX3U Series hardware and information on instructions for PLC programming and special extension unit/block, refer to the relevant documents.

Manual name	Manual No.	Description
FX3U Series User's Manual - Hardware Edition	JY997D16501 MODEL CODE: 09R516	Explains FX3U Series PLC specification details for I/O, wiring, installation, and maintenance.
FX3S/FX3G/FX3GC/FX3U/FX3UC Series Programming Manual - Basic & Applied Instruction Edition	JY997D16601 MODEL CODE: 09R517	Describes PLC programming for basic/applied instructions STL/SFC programming and devices.
MELSEC-Q/L/F Structured Programming Manual (Fundamentals)	SH-080782 MODEL CODE: 13JW06	Programming methods, specifications, functions, etc. required to create structured programs.
FXCPU Structured Programming Manual [Device & Common]	JY997D26001 MODEL CODE: 09R925	Devices, parameters, etc. provided in structured projects of GX Works2.
FXCPU Structured Programming Manual [Basic & Applied Instruction]	JY997D34701 MODEL CODE: 09R926	Sequence instructions provided in structured projects of GX Works2.
FXCPU Structured Programming Manual [Application Functions]	JY997D34801 MODEL CODE: 09R927	Application functions provided in structured projects of GX Works2.

Manual name	Manual No.	Description
FX Series User's Manual - Data Communication Edition	JY997D16901 MODEL CODE: 09R715	Explains N:N link, parallel link, computer link, no protocol communication by RS instructions/FX2N-232IF.
FX3S/FX3G/FX3GC/FX3U/FX3UC Series User's Manual - Analog Control Edition	JY997D16701 MODEL CODE: 09R619	Describes specifications for analog control and programming methods for FX3S/FX3G/FX3GC/FX3U/FX3UC Series PLC.
FX3S/FX3G/FX3GC/FX3U/FX3UC Series User's Manual - Positioning Control Edition	JY997D16801 MODEL CODE: 09R620	Explains the specifications for positioning control of FX3S/FX3G/FX3GC/FX3U/FX3UC Series and programming procedures

Marine standard

Please consult with Mitsubishi Electric for the information on marine standard practices and the corresponding types of equipment.

Certification of UL, cUL standards

FX3U series main units, FX3U series special adapters and FX2N series input/output extension units/blocks supporting UL, cUL standards are as follows:

UL, cUL file number: E95239

Models: MELSEC FX3U series manufactured
 FX3U-**MR/ES(-A) FX3U-**MT/ES(-A)
 FX3U-**MT/ESS
 Where ** indicates: 16, 32, 48, 64, 80, 128
 FX3U-**MR/DS FX3U-**MT/DS
 FX3U-**MT/DSS
 Where ** indicates: 16, 32, 48, 64, 80
 FX3U-**MR/UA1 FX3U-**MS/ES
 Where ** indicates: 32, 64
 FX3U-232ADP(-MB) FX3U-485ADP(-MB)
 FX3U-4AD-ADP FX3U-4DA-ADP
 FX3U-3A-ADP FX3U-4AD-PT-ADP
 FX3U-4AD-PTW-ADP FX3U-4AD-PNK-ADP
 FX3U-4AD-TC-ADP
 FX3U-4HSX-ADP FX3U-2HSY-ADP
 FX3U-CF-ADP FX3U-ENET-ADP

Models: MELSEC FX2N series manufactured
 FX2N-**ER-ES/UL FX2N-**ET-ESS/UL
 Where ** indicates: 32, 48
 FX2N-48ER-DS FX2N-48ET-DSS
 FX2N-48ER-UA1/UL
 FX2N-8ER-ES/UL FX2N-8EX-ES/UL
 FX2N-8EYR-ES/UL FX2N-8EYR-S-ES/UL
 FX2N-8EYT-ESS/UL FX2N-8EX-UA1/UL
 FX2N-16EX-ES/UL FX2N-16EYR-ES/UL
 FX2N-16EYT-ESS/UL FX2N-16EYS

Compliance with EC directive (CE Marking)

This product complies with EC directive, however, this document does not guarantee that a mechanical system including this product will comply with EC directive.

Compliance to EMC directive and LVD directive of the entire mechanical system should be checked by the user/manufacturer. For more details please contact the local Mitsubishi Electric sales site.

Caution for compliance with EC Directive

- Please use the FX3U Series programmable controllers while installed in conductive shielded control panels under a general industrial environment.
- Programmable controllers are open-type devices that must be installed and used within conductive control panels. Please secure the control box lid to the control box (for conduction). Installation within a control box greatly affects the safety of the system and aids in shielding noise from the programmable controller.
- For the control panel, use the product having sufficient strength, fire protectiveness and shielding property to an installation environment.
- 24 V DC of the power supply must be supplied from the circuit double/reinforced insulated from the main power supply (MAINS).

Caution for compliance with the LVD directive (EN61010-2-201:2013) (*1)

- To an external connection port other than AC power supply terminal and AC input/output terminal, connect the circuit separated from a dangerous voltage by a double/reinforced insulation.
- Between the commons having the adjacent relay output terminals, if an external power supply is higher than 120 V AC, the insulation is basic. Therefore, when using 120 V AC or higher external power supply and 30 V DC/AC or lower external power supply between the adjacent commons, do not handle 30 V DC/AC or lower external power supply as a touchable part. (When handling 30 V DC/AC or lower external power supply as a touchable part, add a basic insulation.)
- Do not wire two or more crimp terminals to one terminal. (If the wiring with two or more wires is needed, take an appropriate action such as adding an external terminal.)
- For crimp terminals to be used for the wiring applied with 30 V AC or higher, use the products with insulating sleeves.
- Cutoff device such as a breaker or a circuit protector should be installed in accordance with the following precautions.
 - Use EN60947-1 or EN60947-3 standards.
 - Place the cutoff device so that it can be operated easily.
 - Specify that the cutoff device is for this equipment.

(*1) For the time of compliance with the LVD directive (EN61010-2-201:2013), refer to FX3U Series User's Manual - Hardware Edition.

Caution for Analog Products in use

The analog special adapters have been found to be compliant to the European standards in the aforesaid manual and directive. However, for the very best performance from what are in fact delicate measuring and controlled output device Mitsubishi Electric would like to make the following points;

As analog devices are sensitive by nature, their use should be considered carefully. For users of proprietary cables (integral with sensors or actuators), these users should follow those manufacturers installation requirements.

Mitsubishi Electric recommend that shielded cables should be used. If NO other EMC protection is provided, then users may experience temporary induced errors not exceeding +10 %/-10 % in very heavy industrial areas.

However, Mitsubishi Electric suggest that if adequate EMC precautions are followed with general good EMC practice for the users complete control system, users should expect normal errors as specified in this manual.

- Sensitive analog cable should not be laid in the same trunking or cable conduit as high voltage cabling. Where possible users should run analog cables separately.
- Good cable shielding should be used. When terminating the shield at Earth - ensure that no earth loops are accidentally created.
- When reading analog values, EMC induced errors can be smoothed out by averaging the readings. This can be achieved either through functions on the analog special adapter/block or through a users program in the FX3U Series PLC main unit.

Incorporated Items

Check if the following product and items are included in the package:

		Included Items	
■ Main units			
FX3U-16M□ to FX3U-128M□	Product		1 unit
	Dust proof protection sheet		1 sheet
	Manuals [Japanese (*1)/English]		1 manual
■ Input/output extension units			
FX2N-32E□, FX2N-48E□	Product		1 unit
	Extension cable		1 cable
	Input/output number label		1 sheet
■ Input/output extension blocks			
FX2N-8E□, FX2N-16E□	Product		1 unit
	Input/output number label		1 sheet

(*1) The FX3U-□□□□/ES-A becomes Chinese version.

1. Outline

1.1 Part names

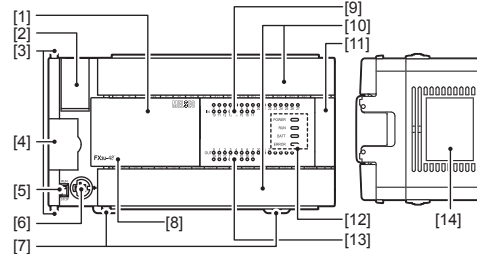

No.	Name		
[1]	Top cover		
[2]	Battery cover		
[3]	Special adapter connecting hooks (2 places)		
[4]	Expansion board dummy cover		
[5]	RUN/STOP switch		
[6]	Peripheral device connecting connector		
[7]	DIN rail mounting hooks		
[8]	Model name (abbreviation)		
[9]	Input display LEDs (Red)		
[10]	Terminal block covers		
[11]	Extension device connecting connector cover		
[12]	Operation status display LEDs		
	POWER	Green	On while power is on the PLC.
	RUN	Green	On while the PLC is running.
	BATT	Red	Lights when the battery voltage drops.
		Red	Flashing when a program error occurs.
[13]	ERROR		Red
			Red
[13]	Output display LEDs (Red)		
[14]	Nameplate printing		
	△ is a mark that instructs to use the cable with an appropriate temperature rating (80°C or more) for wiring.		

With terminal cover open

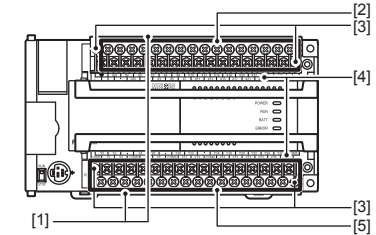

No.	Name
[1]	Protective terminal covers (FX3U-□□□□-A is excluded)
[2]	Power supply, Input (X) terminals
[3]	Terminal block mounting screws (FX3U-16M□ terminal block cannot be installed/removed)
[4]	Terminal names △ shows a function grounding terminal.
[5]	Output (Y) terminals

1.2 External dimensions and weight

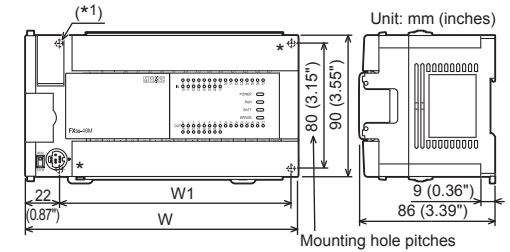

- (*1) 2-φ4.5-diam mounting holes: FX3U-16M□, FX3U-32M□ (except FX3U-32MR/UA1)
- 4-φ4.5-diam mounting holes: FX3U-48M□, FX3U-64M□, FX3U-80M□, FX3U-128M□, FX3U-32MR/UA1
- FX3U-16M□ and FX3U-32M□ (except FX3U-32MR/UA1) do not have the (*)-marked mounting holes.

Model name	W: mm (inches)	W1: mm (inches) Direct mounting hole pitches	MASS (Weight): kg (lbs)
FX3U-16M□	130 (5.12")	103 (4.06")	0.6 (1.32lbs)
FX3U-32M□ (*2)	150 (5.91")	123 (4.85")	0.65 (1.43lbs)
FX3U-48M□	182 (7.17")	155 (6.11")	0.85 (1.87lbs)
FX3U-64M□ (*3)	220 (8.67")	193 (7.6")	1.00 (2.2lbs)
FX3U-80M□	285 (11.23")	258 (10.16")	1.20 (2.64lbs)
FX3U-128M□	350 (13.78")	323 (12.72")	1.80 (3.96lbs)

(*2) FX3U-32MR/UA1 is equivalent to FX3U-48M□.

(*3) FX3U-64MR/UA1 is equivalent to FX3U-80M□.

Installation

- 35-mm-wide DIN rail or Direct (screw) mounting (M4)

2. Installation (general specifications)

As for installation of the input/output extension units/blocks, special adapters and expansion boards, refer to FX3U Series User's Manual - Hardware Edition.

INSTALLATION PRECAUTIONS	CAUTION
<ul style="list-style-type: none"> Use the product within the generic environment specifications described in section 2.1 of this manual. Never use the product in areas with excessive dust, oily smoke, conductive dusts, corrosive gas (salt air, Cl₂, H₂S, SO₂ or NO₂), flammable gas, vibration or impacts, or expose it to high temperature, condensation, or rain and wind. If the product is used in such conditions, electric shock, fire, malfunctions, deterioration or damage may occur. Do not touch the conductive parts of the product directly. Doing so may cause device failure or malfunctions. Install the product securely using a DIN rail or mounting screws. Install the product on a flat surface. If the mounting surface is rough, undue force will be applied to the PC board, thereby causing nonconformities. 	

INSTALLATION PRECAUTIONS	CAUTION
<ul style="list-style-type: none"> When drilling screw holes or wiring, make sure cutting or wire debris does not enter the ventilation slits. Failure to do so may cause fire, equipment failures or malfunctions. Be sure to remove the dust proof sheet from the PLC's ventilation port when installation work is completed. Failure to do so may cause fire, equipment failures or malfunctions. Connect the extension cables, peripheral device cables, input/output cables and battery connecting cable securely to their designated connectors. Loose connections may cause malfunctions. Turn off the power to the PLC before attaching or detaching the following devices. Failure to do so may cause device failures or malfunctions. <ul style="list-style-type: none"> Peripheral devices, display modules, expansion boards and special adapters Extension units/blocks and the FX Series terminal block Battery and memory cassette 	

Notes
<ul style="list-style-type: none"> When a dust proof sheet is supplied with an unit, keep the sheet applied to the ventilation slits during installation and wiring work. To prevent temperature rise, do not install the PLC on a floor, a ceiling or a vertical surface. Install it horizontally on a wall as shown in section 2.2. Keep a space of 50 mm (1.97") or more between the unit main body and another device or structure (part A). Install the unit as far away as possible from high-voltage lines, high-voltage devices and power equipment. Failure to do so may cause fire, equipment failures or malfunctions.

WIRING PRECAUTIONS	WARNING
<ul style="list-style-type: none"> Cut off all phases of the power supply externally before installation or wiring work in order to avoid damage to the product or electric shock. 	

2.1 Generic specifications

Item	Specification				
Ambient temperature	0 to 55 °C (32 to 131 °F) when operating and -25 to 75 °C (-13 to 167 °F) when stored				
Ambient humidity	5 to 95 %RH (no condensation) when operating				
Vibration resistance (*1)	When installed on DIN rail	10 to 57	-	0.035	Sweep Count for X, Y, Z: 10 times (80 min in each direction)
		57 to 150	4.9	-	
	When installed directly	10 to 57	-	0.075	
		57 to 150	9.8	-	
Shock resistance (*1)	147 m/s ² Acceleration, Action time: 11 ms, 3 times by half-sine pulse in each direction X, Y, and Z				
Noise resistance	By noise simulator at noise voltage of 1,000 Vp-p, noise width of 1 μs, rise time of 1 ns and period of 30 to 100 Hz				
Dielectric withstand voltage (*2)	1.5 kV AC for one minute	Between each terminals and ground terminal			
	500 V AC for one minute				
Insulation resistance (*2)	5 MΩ or higher by 500 V DC insulation resistance tester				
Grounding	Class D grounding (grounding resistance: 100 Ω or less) <Common grounding with a heavy electrical system is not allowed.> (*3)				
Working atmosphere	Free from corrosive or flammable gas and excessive conductive dusts				
Working altitude	<2000 m (*4)				
Installation location	Inside a control panel (*5)				
Over voltage category	II or less				
Pollution degree	2 or less				

(*1) The criterion is shown in IEC61131-2.

(*2) Dielectric withstand voltage and insulation resistance are shown in the following table.

Terminal	Dielectric strength	Insulation resistance	
■ Main units, Input/output extension units/blocks			
Between power supply terminal (AC power) and ground terminal	1.5 kV AC for one minute	5 MΩ or higher by 500 V DC insulation resistance tester	
Between power supply terminal (DC power) and ground terminal	500 V AC for one minute		
Between 24 V DC service power supply connected to input terminal (24 V DC) and ground terminal	500 V AC for one minute		
Between input terminal (100 V AC) and ground terminal	1.5 kV AC for one minute		
Between output terminal (relay) and ground terminal	1.5 kV AC for one minute		
Between output terminal (transistor) and ground terminal	500 V AC for one minute		
Between output terminal (triac) and ground terminal	1.5 kV AC for one minute		
■ Expansion boards, Special adapters, Special function units/blocks			
Between terminal of expansion board and ground terminal	Not allowed		Not allowed
Between terminal of special adapter and ground terminal	500 V AC for 1 min		5 MΩ or higher by 500 V DC insulation resistance tester
Special function unit/block	Each manual		

For dielectric with stand voltage test and insulation resistance test of each product, refer to the following manual.

→ **Refer to FX3U Series User's Manual - Hardware Edition.**

(*3) For common grounding, refer to section 3.3.

(*4) The PLC cannot be used at a pressure higher than the atmospheric pressure to avoid damage.

(*5) The programmable controller is assumed to be installed in an environment equivalent to indoor.

2.2 Installation location

Install the PLC in an environment conforming to the generic specifications (section 2.1), installation precautions and notes.

For more details, refer to FX3U Series User's Manual - Hardware Edition.

Installation location in enclosure

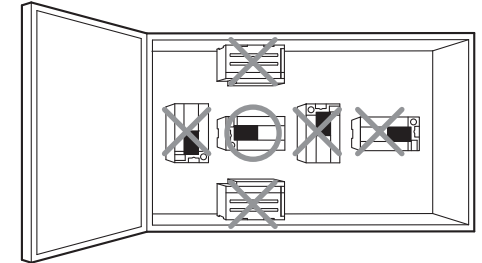

Space in enclosure

Extension devices can be connected on the left and right sides of the main unit of the PLC.

If you intend to add extension devices in the future, keep necessary spaces on the left and right sides.

Configuration without extension cable

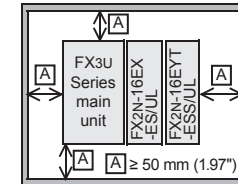

Configuration in 2 stages with extension cable

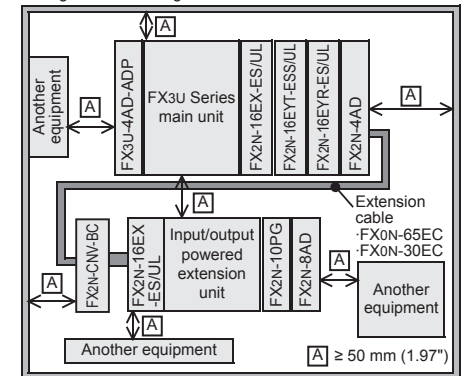

2.2.1 Affixing the dust proof sheet

The dust proof sheet should be affixed to the ventilation port before beginning the installation and wiring work.

→ **For the affixing procedure, refer to the instructions on the dust proof sheet.**

Be sure to remove the dust proof sheet when the installation and wiring work is completed.

2.3 Procedures for installing to and detaching from DIN rail

The products can be installed on a DIN46277 rail [35 mm (1.38") wide]. This section explains the installations of the main units. For the input/output extension units/blocks and special adapters, refer to the following manual.

→ Refer to FX3U Series User's Manual - Hardware Edition.

2.3.1 Installation

- 1) Connect the expansion boards and special adapters to the main unit.
- 2) Push out all DIN rail mounting hooks (below fig.A)

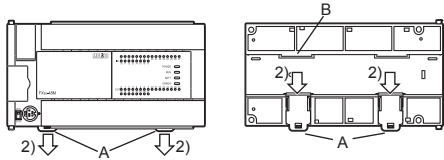

- 3) Fit the upper edge of the DIN rail mounting groove (right fig.B) onto the DIN rail.

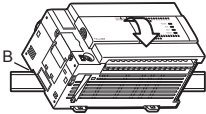

- 4) Lock the DIN rail mounting hooks (below fig.C) while pressing the PLC against the DIN rail.

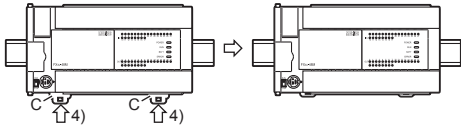

2.4 Procedures for installing directly (with M4 screws)

The product can be installed directly on the panel (with screws). This section explains the installation of the main units. As for the details of the installation/detaching for input extension units/blocks and special adapters, refer to the following manual.

→ Refer to FX3U Series User's Manual - Hardware Edition.

2.4.1 Mounting hole pitches

Refer to the External Dimensions (section 1.2) for the product's mounting hole pitch information.

As for the details of the mounting hole pitches for extension unit/block and special adapters, refer to the following manual.

→ Refer to FX3U Series User's Manual - Hardware Edition.

2.4.2 Installation

- 1) Make mounting holes in the mounting surface referring to the external dimensions diagram.
- 2) Fit the main unit (A in the right figure) based on the holes, and secure it with M4 screws (B in the right figure). The mounting hole pitches and number of screws depend on the product. Refer to the external dimensions diagram.

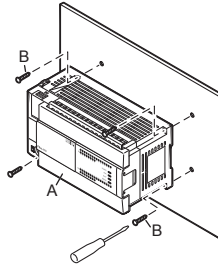

3. Power supply/input/output specifications and examples of external wiring

As for the details of the power supply wiring and input/output wiring, refer to FX3U Series User's Manual - Hardware Edition.

DESIGN PRECAUTIONS **WARNING**

- Make sure to have the following safety circuits outside of the PLC to ensure safe system operation even during external power supply problems or PLC failure. Otherwise, malfunctions may cause serious accidents.

- 1) Most importantly, have the following: an emergency stop circuit, a protection circuit, an interlock circuit for opposite movements (such as normal vs. reverse rotation), and an interlock circuit (to prevent damage to the equipment at the upper and lower positioning limits).
- 2) Note that when the PLC CPU detects an error, such as a watchdog timer error, during self-diagnosis, all outputs are turned off. Also, when an error that cannot be detected by the PLC CPU occurs in an input/output control block, output control may be disabled. External circuits and mechanisms should be designed to ensure safe machinery operation in such a case.
- 3) Note that the output current of the 24 V DC service power supply varies depending on the model and the absence/presence of extension blocks. If an overload occurs, the voltage automatically drops, inputs in the PLC are disabled, and all outputs are turned off. External circuits and mechanisms should be designed to ensure safe machinery operation in such a case.
- 4) Note that when an error occurs in a relay, triac or transistor output device, the output could be held either on or off. For output signals that may lead to serious accidents, external circuits and mechanisms should be designed to ensure safe machinery operation in such a case.

DESIGN PRECAUTIONS **CAUTION**

- Do not bundle the control line together with or lay it close to the main circuit or power line. As a guideline, lay the control line at least 100 mm (3.94") or more away from the main circuit or power line. Noise may cause malfunctions.
- Install module so that excessive force will not be applied to peripheral device connectors. Failure to do so may result in wire damage/breakage or PLC failure.

Notes

- Simultaneously turn on and off the power supplies of the main unit and extension devices.
- Even if the AC power supply causes an instantaneous power failure for less than 10 ms, the PLC can continue to operate.
- Even if the DC power supply causes an instantaneous power failure for less than 5ms, the PLC can continue to operate.
- If a long-time power failure or an abnormal voltage drop occurs, the PLC stops, and output is turned off. When the power supply is restored, it will automatically restart (when the RUN input is on).

WIRING PRECAUTIONS **WARNING**

- Make sure to cut off all phases of the power supply externally before installation or wiring work. Failure to do so may cause electric shock or damage to the product.
- The temperature rating of the cable should be 80°C or more.

WIRING PRECAUTIONS **CAUTION**

- Connect the AC power supply to the dedicated terminals described in this manual. If an AC power supply is connected to a DC input/output terminal or DC power supply terminal, the PLC will burn out.
- Do not wire vacant terminals externally. Doing so may damage the product.
- Perform class D grounding (grounding resistance: 100 Ω or less) to the grounding terminal on the FX3U PLC main unit with a wire 2 mm² or thicker. Do not use common grounding with heavy electrical systems (refer to section 3.3).
- When drilling screw holes or wiring, make sure cutting or wire debris does not enter the ventilation slits. Failure to do so may cause fire, equipment failures or malfunctions.
- Make sure to properly wire to the terminal in accordance with the following precautions. Failure to do so may cause electric shock, equipment failures, a short-circuit, wire breakage, malfunctions, or damage to the product.
 - The disposal size of the cable end should follow the dimensions described in the manual.
 - Tightening torque should follow the specifications in the manual.

Notes

- Input/output wiring 50 to 100 m (164'1" to 328'1") long will cause almost no problems of noise, but, generally, the wiring length should be less than 20 m (65'7") to ensure the safety.
- Extension cables are easily affected by noise. Lay the cables at a distance of at least 30 to 50 mm (1.19" to 1.97") away from the PLC output and other power lines.

3.1 Wiring

3.1.1 Cable end treatment and tightening torque

For the terminals of FX3U series PLC, M3 screws are used. The electric wire ends should be treated as shown below. Tighten the screws to a torque of 0.5 to 0.8 N•m.

Do not tighten terminal screws with a torque outside the above-mentioned range.

Failure to do so may cause equipment failures or malfunctions.

- When one wire is connected to one terminal

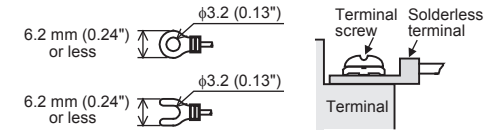

<Reference>

Terminal manufacturer	Type No.	Applicable cable	Certification	Pressure bonding tool
J.S.T. Mfg. Co., Ltd.	FV1.25-B3A	AWG22 to 16	UL Listed	YA-1 (J.S.T. Mfg. Co., Ltd.)
	FV2-MS3	AWG16 to 14		

- When two wires are connected to one terminal(*)

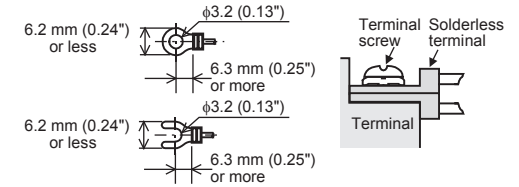

<Reference>

Terminal manufacturer	Type No.	Applicable cable	Certification	Pressure bonding tool
J.S.T. Mfg. Co., Ltd.	FV1.25-B3A	AWG22 to 16	UL Listed	YA-1 (J.S.T. Mfg. Co., Ltd.)

(*) To adapt the LVD directive (EN61010-2-201:2013) of the EC directive, avoid the wiring with two wires to the built-in terminal, and take an appropriate action such as adding an external terminal.

For the time of compliance with the LVD directive (EN61010-2-201:2013), refer to FX3U Series User's Manual - Hardware Edition.

3.1.2 Removal and installation of quick-release terminal block

- Removal** Unscrew the terminal block mounting screw [both right and left screws] evenly, and remove the terminal block.
- Installation** Place the terminal block in the specified position, and tighten the terminal block mounting screw evenly [both right and left screws]. Tightening torque 0.4 to 0.5 N•m. Do not tighten the terminal block mounting screws exceeding with a torque outside the above-mentioned range. Failure to do so may cause equipment failures or malfunctions.
- (*) Pay attention so that the center of the terminal block is not lifted.

3.2 Power supply specifications and example of external wiring

As for the details of the power supply specifications and example of external wiring, refer to the following manual.

→ Refer to **FX3U Series User's Manual - Hardware Edition**.

3.2.1 Power supply specifications [Main unit, Input/output extension units]

Item		Specification	
		AC power type	DC power type (*6)
Supply voltage		100 to 240 V AC	24 V DC
Voltage fluctuation range	Main unit	-15%, +10%	-30%, +20% (*5)
	FX2N-32E□, FX2N-48E□		-30%, +20%
Rated frequency		50/60 Hz	-
Allowable instantaneous power failure time		Operation can be continued upon occurrence of instantaneous power failure for 10 ms or less. (*4)	Operation can be continued upon occurrence of instantaneous power failure for 5 ms or less.
Power fuse	FX3U-16M□ to 32M□ (*7)	250 V 3.15 A	
	FX3U-48M□ to 128M□	250 V 5 A	
	FX2N-32E□	250 V 3.15 A	-
	FX2N-48E□	250 V 5 A	250 V 5 A
Rush current	Main unit	30 A max. 5 ms or less/100 V AC 65 A max. 5 ms or less/200 V AC	35 A max. 0.5 ms or less/24 V DC
	FX2N-32E□, FX2N-48E□	40 A max. 5 ms or less/100 V AC 60 A max. 5 ms or less/200 V AC	-
Power consumption (*1)	FX3U-16M□	30 W	25 W
	FX3U-32M□	35 W	30 W
	FX3U-48M□	40 W	35 W
	FX3U-64M□	45 W	40 W
	FX3U-80M□	50 W	45 W
	FX3U-128M□	65 W	-
24 V DC service power supply (*2)	FX2N-32E□	30 W	-
	FX2N-48E□	35 W	30 W
5 V DC builtin power supply (*3)	FX3U-16M□ to 32M□	400 mA or less	-
	FX3U-48M□ to 128M□	600 mA or less	-
	FX2N-32E□	250 mA	-
FX2N-48E□	Main unit	500 mA or less	-
	FX2N-32E□	690 mA or less	-

- (*1) Does not include the power consumption of extension units/special extension units, and of the extension blocks/special extension blocks connected to those units.
For the power (current) consumed by the extension units/blocks for input/output, refer to FX3U Series User's Manual - Hardware Edition.
For the power consumed by the special extension units/blocks, refer to the appropriate manual.
- (*2) When input/output extension blocks are connected, the 24 V DC service power supply is consumed by the blocks, and the current value to be used by the main unit is reduced.
The AC power (AC input) type and DC power type do not have a service power supply.
- (*3) Cannot be used to supply power to an external destination.
The power is supplied to input/output extension blocks, special extension blocks, special adapters and expansion boards.
The following manual shows further information.
→ Refer to **FX3U Series User's Manual - Hardware Edition**.
- (*4) When the supply voltage is 200 V AC, the time can be changed to 10 to 100 ms by editing the user program.
- (*5) When supply voltage is 16.8-19.2 V DC, the connectable extension equipment decreases. The following manual shows further information.
→ Refer to **FX3U Series User's Manual - Hardware Edition**.
- (*6) When attaching high-speed input/output special adapter (FX3U-4HSX-ADP, FX3U-2HSY-ADP) and special function block (FX0N-3A, FX2N-2AD, FX2N-2DA), the number of connectable modules to the main unit is limited, due to the current consumption (internal 24 V DC) at startup. The following manual shows further information.
→ Refer to **FX3U Series User's Manual - Hardware Edition**.
- (*7) 250 V 5 A is specified for the power fuse of FX3U-32MR/UA1.

3.2.2 Example of external wiring (AC power type)

100 to 240 V AC power is supplied to the main unit and input/output extension units. For the details of wiring work, refer to section 3.1.

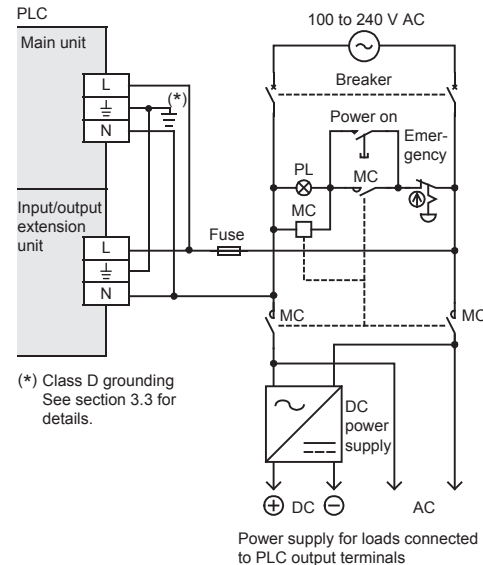

3.2.3 Example of external wiring (DC power type)

24 V DC power is supplied to the main unit and input/output extension unit. For the details of wiring work, refer to section 3.1.

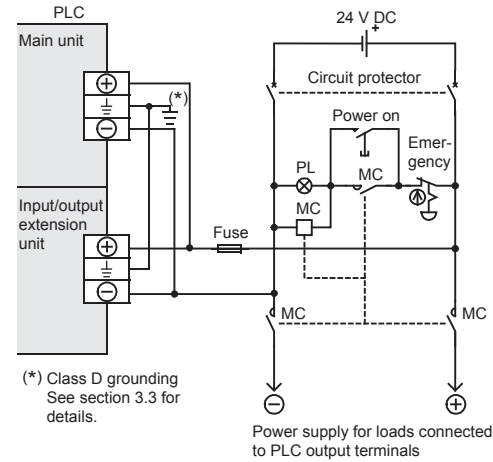

3.3 Grounding

Ground the PLC as stated below.

- Perform class D grounding. (Grounding resistance: 100 Ω or less)
 - Ground the PLC independently if possible.
If it cannot be grounded independently, ground it jointly as shown below.
-
- Use ground wires thicker than AWG14 (2 mm²).
 - Position the grounding point as close to the PLC as possible to decrease the length of the ground wire.

3.4 Input specifications and external wiring

As for the details of the input specifications and external wiring, refer to the following manual.

→ Refer to **FX3U Series User's Manual - Hardware Edition**.

3.4.1 Input specifications (24 V DC input type)

Item	Specification	
Number of input points	FX2N-8ER□	4 points (8 points) (*1)
	FX3U-16M□, FX2N-8EX□	8 points
	FX3U-32M□, FX2N-16EX□, FX2N-32E□	16 points
	FX3U-48M□, FX2N-48E□	24 points
	FX3U-64M□	32 points
	FX3U-80M□, FX3U-128M□	40 points

Item		Specification	
Input connecting type		Refer to FX3U Series User's Manual - Hardware Edition	
Input form			
Input signal voltage	Main units	AC power Type	24 V DC +10 %, -10 %
		DC power Type	24 V DC +20 %, -30 %
	Input/output extension unit	AC power Type	24 V DC +10 %, -10 %
		DC power Type	24 V DC +20 %, -30 %
Input impedance	Main units	X000 to X005	3.9 kΩ
		X006, X007	3.3 kΩ
		X010 or more	4.3 kΩ (Does not apply to FX3U-16M□.)
	Input/output extension unit/block	4.3 kΩ	
Input signal current	Main units	X000 to X005	6 mA/24 V DC
		X006, X007	7 mA/24 V DC
		X010 or more	5 mA/24 V DC (Does not apply to FX3U-16M□.)
	Input/output extension unit/block	5 mA/24 V DC	
ON input sensitivity current	Main units	X000 to X005	3.5 mA or more
		X006, X007	4.5 mA or more
		X010 or more	3.5 mA or more (Does not apply to FX3U-16M□.)
	Input/output extension unit/block	3.5 mA or more/24 V DC	
OFF input sensitivity current		1.5 mA or less	
Input response time		Approx. 10 ms	
Input signal form (Input sensor form)		<ul style="list-style-type: none"> • Sink input: No-voltage contact input NPN open collector transistor • Source input: No-voltage contact input PNP open collector transistor 	
Input circuit insulation		Photocoupler insulation	
Input operation display		LED on panel lights when photocoupler is driven.	

(*1) Each value inside () indicates the number of occupied points.

3.4.2 Examples of 24 V DC input wiring [AC power type]

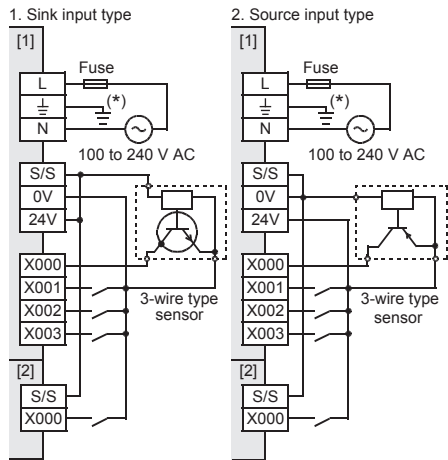

(*1) Class D grounding
See section 3.3 for details.

[1]: Main unit, Input/output extension unit
(Common to both sink and source inputs)

[2]: Input/output extension block
(Common to both sink and source inputs)

3.4.3 Examples of 24 V DC input wiring [DC power type]

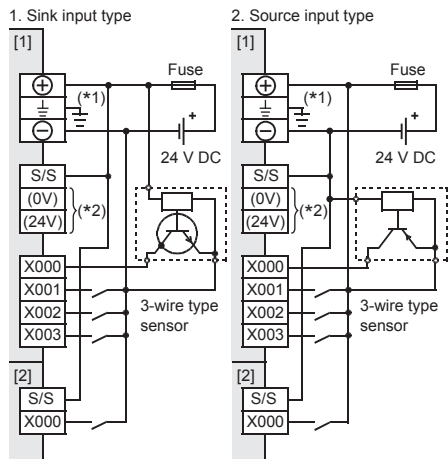

(*1) Class D grounding
See section 3.3 for details.

(*2) Do not connect the (0V), (24V) terminals with others,
since they are not available.

[1]: Main unit, Input/output extension unit
(Common to both sink and source inputs)

[2]: Input/output extension block
(Common to both sink and source inputs)

3.4.4 Instructions for connecting input devices

- In the case of no-voltage contact:
The input current of this PLC is 5 to 7 mA/24 V DC.
Use input devices applicable to this minute current.
If no-voltage contacts (switches) for large current are used,
contact failure may occur.

<Example> Products of OMRON

Type	Model name	Type	Model name
Microswitch	Models Z, V and D2RV	Operation switch	Model A3P
Proximity switch	Model TL	Photoelectric switch	Model E3S

- In the case of input device with built-in series diode:
The voltage drop of the series diode should be approx. 4 V or less.
When lead switches with a series LED are used, up to two switches can be connected in series.
Also make sure that the input current is over the input-sensing level while the switches are ON.

• Sink input

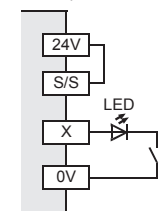

• Source input

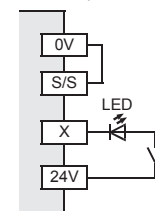

- In the case of input device with built-in parallel resistance:
Use a device having a parallel resistance, Rp, of 15 kΩ or more.
When the resistance is less than 15 kΩ, connect a bleeder resistance, Rb, obtained from the formula as shown in the following figure.

$$R_b \cong \frac{4R_p}{15-R_p} \text{ (k}\Omega\text{)}$$

• Sink input

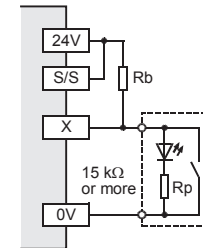

• Source input

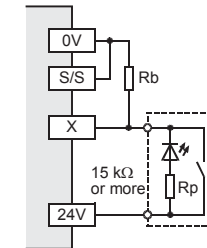

- In the case of 2-wire proximity switch:

Use a two-wire proximity switch whose leakage current, I_l , is 1.5 mA or less when the switch is off.
When the current is larger than 1.5 mA, connect a bleeder resistance, R_b , obtained from formula as shown in the following figure.

$$R_b \cong \frac{6}{I_l - 1.5} \text{ (k}\Omega\text{)}$$

• Sink input

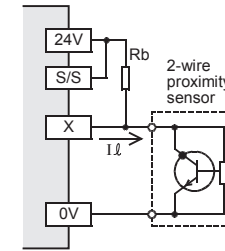

• Source input

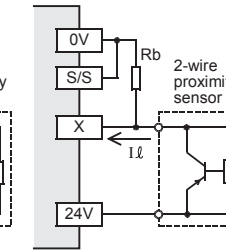

3.4.5 Input specifications (100 V AC input type)

Item		Specification
Number of input points	FX2N-8EX-UA1/UL	8 points
	FX3U-32MR/UA1	16 points
	FX2N-48ER-UA1/UL	24 points
	FX3U-64MR/UA1	32 points
Input connecting type		Refer to FX3U Series User's Manual - Hardware Edition
Input form		Refer to FX3U Series User's Manual - Hardware Edition
Input signal voltage		100 to 120 V AC +10 %, -15 % 50/60 Hz
Input impedance		Approx. 21 kΩ/50 Hz Approx. 18 kΩ/60 Hz
Input signal current		4.7 mA/100 V AC 50 Hz 6.2 mA/110 V AC 60 Hz (70 % or less when turned on simultaneously)
ON input sensitivity current		3.8 mA or more
OFF input sensitivity current		1.7 mA or less
Input response time		Approx. 25 to 30 ms (A high speed receiving is improper)
Input signal form		Contact input
Input circuit insulation		Photocoupler insulation
Input operation display		LED on panel lights when photocoupler is driven.

3.4.6 Examples of 100V AC input wiring

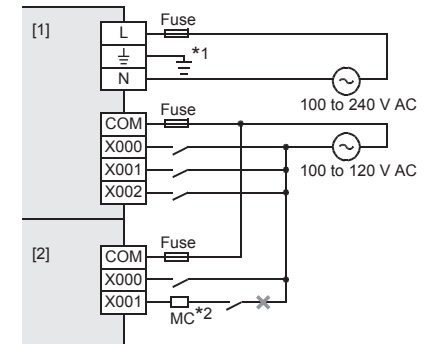

*1 Class D grounding See section 3.3 for details.

*2 Do not take input signals from loads generating surge.

[1]: Main unit, Input/output extension unit
(100 V AC input type)

[2]: Input extension block
(100 V AC input type)

3.5 Relay output specifications and example of external wiring

As for the details of Instructions for connecting input devices, refer to the following manual.

→ Refer to FX3U Series User's Manual - Hardware Edition.

3.5.1 Relay output specifications

Item		Specification
Number of output points	FX2N-8ER□	4 points (8 points) (*1)
	FX3U-16MR□, FX2N-8EYR□	8 points
	FX3U-32MR□, FX2N-32ER□, FX2N-16EYR□	16 points
	FX3U-48MR□, FX2N-48ER□	24 points
	FX3U-64MR□	32 points
	FX3U-80MR□	40 points
	FX3U-128MR/ES	64 points
	Output connecting type	
Output form		Relay
External power supply		30 V DC or less 240 V AC or less ("250 V AC or less" if not a CE, UL, cUL compliant item)
Max. load	Resistance load	2 A/point (*2)
	Inductive load	80 VA
Min. load		5 V DC, 2 mA (reference value)
Open circuit leakage current		-
Response time	OFF→ON	Approx. 10 ms
	ON→OFF	Approx. 10 ms
Output circuit insulation		Mechanical insulation
Output operation display		LED on panel lights when power is applied to relay coil.

(*1) Each value inside () indicates the number of occupied points.

(*2) The total load current of resistance loads per common terminal should be the following value.

- 1 output point/common terminal: 2 A or less
- 4 output points/common terminal: 8 A or less
- 8 output points/common terminal: 8 A or less

As for the number of outputs per common terminal, refer to "Chapter 4 interpretation of partition" and the following manual.
→ Refer to FX3U Series User's Manual - Hardware Edition.

3.5.2 Life of relay output contact

The product life of relay contacts considerably varies depending on the load type used. Take care that loads generating reverse electromotive force or rush current may cause poor contact or deposition of contacts which may lead to considerable reduction of the contact product life.

1) Inductive load

Inductive loads generate large reverse electromotive force between contacts at shutdown which may cause arcing. At a fixed current consumption, as the power factor (phase between current and voltage) gets smaller, the arc energy gets larger. The standard life of the contact used for inductive loads, such as contactors and solenoid valves, is 500 thousand operations at 20 VA.

The following table shows the approximate life of the relay based on the results of our operation life test.

Test condition: 1 sec.ON / 1 sec.OFF.

Load capacity		Contact life
20 VA	0.2 A/100 V AC	3 million times
	0.1 A/200 V AC	
35 VA	0.35 A/100 V AC	1 million times
	0.17 A/200 V AC	
80 VA	0.8 A/100 V AC	2 hundred thousand times
	0.4 A/200 V AC	

The product life of relay contacts becomes considerably shorter than the above conditions when the rush overcurrent is shut down.

→ For countermeasures while using inductive loads, refer to Subsection 3.5.4.

Some types of inductive loads generate rush current 5 to 15 times the stationary current at activation. Make sure that the rush current does not exceed the current corresponding to the maximum specified resistance load.

2) Lamp load

Lamp loads generally generate rush current 10 to 15 times the stationary current. Make sure that the rush current does not exceed the current corresponding to the maximum specified resistance load.

3) Capacitive load

Capacitive loads can generate rush current 20 to 40 times the stationary current. Make sure that the rush current does not exceed the current corresponding to the maximum specified resistance load. Capacitive loads such as capacitors may be present in electronic circuit loads including inverters.

→ For the maximum specified resistance load, refer to Subsection 3.5.1.

3.5.3 Example of relay output wiring

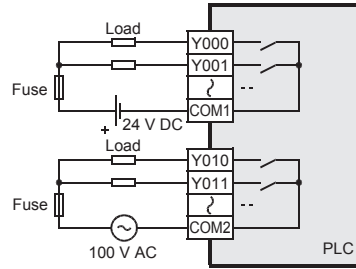

3.5.4 Cautions in external wiring

For cautions in external wiring, refer to the following manual.

→ Refer to FX3U Series User's Manual - Hardware Edition.

Protection circuit for load short-circuiting

When a load connected to the output terminal short-circuits, the printed circuit board may be burnt out. Fit a protective fuse on the output circuit.

Protection circuit of contact when inductive load is used

An internal protection circuit for the relays is not provided for the relay output circuit. It is recommended to use inductive loads with built-in protection circuits. When using loads without built-in protection circuits, insert an external contact protection circuit, etc. to reduce noise and extend the product life.

1) DC circuit

Connect a diode in parallel with the load.

Use a diode (for commutation) having the following specifications.

Item	Standard
Reverse voltage	5 to 10 times the load voltage
Forward current	Load current or more

2) AC circuit

Connect the surge absorber (combined CR components such as a surge killer and spark killer, etc.) parallel to the load.

Select the rated voltage of the surge absorber suitable to the output used. Refer to the table below for other specifications.

Item	Standard
Electrostatic capacity	Approx. 0.1 μF
Resistance value	Approx. 100 to 200 Ω

Interlock

Loads, such as contactors for normal and reverse rotations, that must not be turned on simultaneously should have an interlock in the PLC program and an external interlock.

Common mode

Use output contacts of the PLC in the common mode.

3.6 Transistor output specifications and example of external wiring

As for the details of the transistor output specifications and external wiring, refer to the following manual.

→ Refer to FX3U Series User's Manual - Hardware Edition.

3.6.1 Transistor output specifications

Item		Specification	
Number of output points	FX3U-16MT/□, FX2N-8EYT□	8 points	
	FX3U-32MT/□, FX2N-32ET□, FX2N-16EYT□	16 points	
	FX3U-48MT/□, FX2N-48ET□	24 points	
	FX3U-64MT/□	32 points	
	FX3U-80MT/□	40 points	
	FX3U-128MT/ES(S)	64 points	
Output connecting type		Refer to FX3U Series User's Manual - Hardware Edition	
Output form	FX3U-□□MT/□□S(-A), FX2N-□□ET, FX2N-48ET-D, FX2N-□□EYT, FX2N-8EYT-H	Transistor (Sink)	
	FX3U-□□MT/□□SS, FX2N-□□ET-ESS/UL, FX2N-48ET-DSS, FX2N-□□EYT-ESS/UL	Transistor (Source)	
External power supply		5-30 V DC	
Max. load	Resistance load	FX3U-□□MT/□, FX2N-□□ET, FX2N-□□ET-□, FX2N-□□EYT, FX2N-□□EYT-ESS/UL	0.5 A/point (*1)
		FX2N-8EYT-H	1 A/point (*2)
	Inductive load	FX2N-16EYT-C	0.3 A/point (*3)
		FX3U-□□MT/□, FX2N-□□ET, FX2N-□□ET-□, FX2N-□□EYT, FX2N-□□EYT-ESS/UL	12 W/24 V DC (*4)
	FX2N-8EYT-H	24 W/24 V DC (*5)	
	FX2N-16EYT-C	7.2 W/24 V DC (*6)	
Min. load		-	
Open circuit leakage current		0.1 mA or less/30 V DC	
ON voltage		1.5 V or less	

Item			Specification
Response time	OFF → ON	Main unit	Y000 to Y002: 5 μs or less/10 mA or more (5-24 V DC)
		Y003 or more	0.2 ms or less/200 mA or more (at 24 V DC)
	Input/output extension units/blocks (*7)		0.2 ms or less/200 mA or more (at 24 V DC)
	ON → OFF	Main unit	Y000 to Y002: 5 μs or less/10 mA or more (5-24 V DC)
Y003 or more		0.2 ms or less/200 mA or more (at 24 V DC)	
Input/output extension units/blocks (*7)		0.2 ms or less/200 mA or more (at 24 V DC)	
Output circuit insulation			Photocoupler insulation
Output operation display			LED on panel lights when photocoupler is driven.

(*1) The total load current of resistance loads per common terminal should be the following value.

- 1 output point/common terminal: 0.5 A or less
- 4 output points/common terminal: 0.8 A or less
- 8 output points/common terminal: 1.6 A or less

As for the number of outputs per common terminal, refer to "Chapter 4 interpretation of partition" and the following manual.
→ Refer to FX3U Series User's Manual - Hardware Edition.

(*2) The total load current of resistance loads per common terminal should be the following value.

- 4 output points/common terminal: 2 A or less

As for the number of outputs per common terminal, refer to the following manual.
→ Refer to FX3U Series User's Manual - Hardware Edition.

(*3) The total load current of resistance loads per common terminal should be the following value.

- 16 output point/common terminal: 1.6 A or less

As for the number of outputs per common terminal, refer to the following manual.
→ Refer to FX3U Series User's Manual - Hardware Edition.

(*4) The total of inductive loads per common terminal should be the following value.

- 1 output point/common terminal: 12 W or less/24 V DC
- 4 output points/common terminal: 19.2 W or less/24 V DC
- 8 output points/common terminal: 38.4 W or less/24 V DC

As for the number of outputs per common terminal, refer to "Chapter 4 interpretation of partition" and the following manual.
→ Refer to FX3U Series User's Manual - Hardware Edition.

(*5) The total of inductive loads per common terminal should be the following value.

- 4 output points/common terminal: 48 W or less/24 V DC

As for the number of outputs per common terminal, refer to the following manual.

→ Refer to FX3U Series User's Manual - Hardware Edition.

(*6) The total of inductive loads per common terminal should be the following value.

- 16 output points/common terminal: 38.4 W or less

As for the number of outputs per common terminal, refer to the following manual.

→ Refer to FX3U Series User's Manual - Hardware Edition.

(*7) The response time is as follows in the FX2N-8EYT-H.

- OFF→ON: 0.2 ms or less/1 A
- ON→OFF: 0.4 ms or less/1 A

3.6.2 External wiring of transistor output

1. External wiring of sink output type

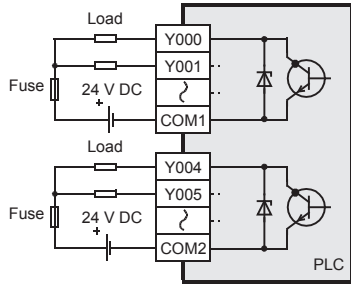

2. External wiring of source output type

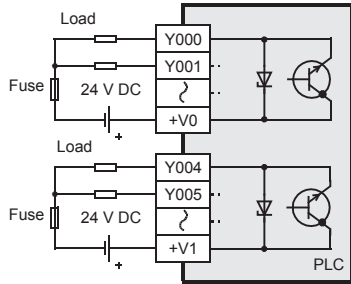

3.6.3 Cautions in external wiring

For cautions in external wiring, refer to the following manual.
→ Refer to FX3U Series User's Manual - Hardware Edition.

Protection circuit for load short-circuits

A short-circuit at a load connected to an output terminal could cause burnout at the output element or the PCB. To prevent this, a protection fuse should be inserted at the output. Use a load power supply capacity that is at least 2 times larger than the total rated fuse capacity.

Contact protection circuit for inductive loads

When an inductive load is connected, connect a diode (for commutation) in parallel with the load as necessary. The diode (for commutation) must comply with the following specifications.

Item	Guide
Reverse voltage	5 to 10 times of the load voltage
Forward current	Load current or more

Interlock

Loads, such as contactors for normal and reverse rotations, that must not be turned on simultaneously should have an interlock in the PLC program and an external interlock.

3.7 Triac output specifications and example of external wiring

As for the details of the triac output specifications and external wiring, refer to the following manual.
→ Refer to FX3U Series User's Manual - Hardware Edition.

3.7.1 Triac output specifications

Item		Specification
Number of output points	FX3U-32MS/ES, FX2N-16EYS, FX2N-32ES	16 points
	FX3U-64MS/ES	32 points
Output connecting type		Refer to FX3U Series User's Manual - Hardware Edition
Output form		Triac (SSR)
External power supply		85 to 242 V AC
Max. load	Resistance load	0.3 A/point (*1)
	Inductive load	15 VA/100 V AC, 30 VA/200 V AC
Min. load		0.4 VA/100 V AC, 1.6 VA/200 V AC
Open circuit leakage current		1 mA/100 V AC, 2 mA/200 V AC
Response time	OFF→ON	1 ms or less
	ON→OFF	10 ms or less
Output circuit insulation		Photo-thyristor insulation
Output operation display		LED on panel lights when photo-thyristor is driven.

(*1) The total load current of resistance loads per common terminal should be the following value.
- 4 output points/common terminal: 0.8 A or less
- 8 output points/common terminal: 0.8 A or less
As for the number of outputs per common terminal, refer to "Chapter 4 interpretation of partition" and the following manual.
→ Refer to FX3U Series User's Manual - Hardware Edition.

3.7.2 External wiring of triac output

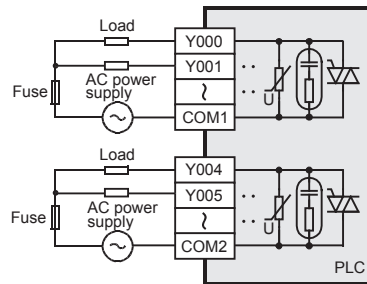

3.7.3 Cautions in external wiring

For cautions in external wiring, refer to the following manual.
→ Refer to FX3U Series User's Manual - Hardware Edition.

Protection circuit for load short-circuits

A short-circuit at a load connected to an output terminal could cause burnout at the output element or the PCB. To prevent this, a protection fuse should be inserted at the output.

Micro current load

The PLC's internal Triac output circuit is equipped with a turn-off C-R absorber. When connecting a very low current load of "0.4 VA/100 V AC or less, or 1.6 VA/200 V AC or less", please connect a surge absorber parallel to the load.

Select the rated voltage of a surge absorber that is suitable for the load being used. Refer to the table below for other specifications.

Item	Guide
Static electricity capacity	Approx. 0.1 μF
Resistance value	Approx. 100 to 200 Ω

Interlock

Loads, such as contactors for normal and reverse rotations, that must not be turned on simultaneously should have an interlock in the PLC program and an external interlock.

4. Terminal block layouts

For details on the terminal block layout, refer to the following manual.
→ Refer to FX3U Series User's Manual - Hardware Edition.

Interpretation of partition

The partition of the output terminals (see following figure) indicates the range of the output connected to the same common.

Example: FX3U-48MT/ES

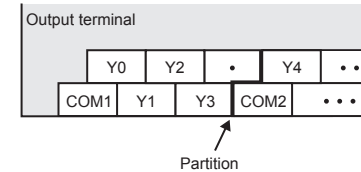

This manual confers no industrial property rights or any rights of any other kind, nor does it confer any patent licenses. Mitsubishi Electric Corporation cannot be held responsible for any problems involving industrial property rights which may occur as a result of using the contents noted in this manual.

Warranty

Exclusion of loss in opportunity and secondary loss from warranty liability
Regardless of the gratis warranty term, Mitsubishi shall not be liable for compensation to:
(1) Damages caused by any cause found not to be the responsibility of Mitsubishi.
(2) Loss in opportunity, lost profits incurred to the user by Failures of Mitsubishi products.
(3) Special damages and secondary damages whether foreseeable or not, compensation for accidents, and compensation for damages to products other than Mitsubishi products.
(4) Replacement by the user, maintenance of on-site equipment, start-up test run and other tasks.

⚠ For safe use

- This product has been manufactured as a general-purpose part for general industries, and has not been designed or manufactured to be incorporated in a device or system used in purposes related to human life.
- Before using the product for special purposes such as nuclear power, electric power, aerospace, medicine or passenger movement vehicles, consult with Mitsubishi Electric.
- This product has been manufactured under strict quality control. However when installing the product where major accidents or losses could occur if the product fails, install appropriate backup or failsafe functions in the system.

MITSUBISHI ELECTRIC CORPORATION

HEAD OFFICE : TOKYO BUILDING, 2-7-3 MARUNOUCHI, CHIYODA-KU, TOKYO 100-8310, JAPAN